

Assembly and fitting guide

DML18WB(CARAVAN)



1. Assemble the three-section mast and fix aerial

Assemble the mast by snapping the three sections together. Fix the aerial to the mast using the clamp assembly as shown. Check that all fixings are tight. The diagram shows the aerial positioned for horizontal polarisation (see section 5). For vertical polarisation turn the aerial through 90° from the position shown. This aerial will provide good reception in many locations when mounted in a clear outdoor position. However reception in weaker signal areas may require the use of a higher gain aerial and/or a taller mast.

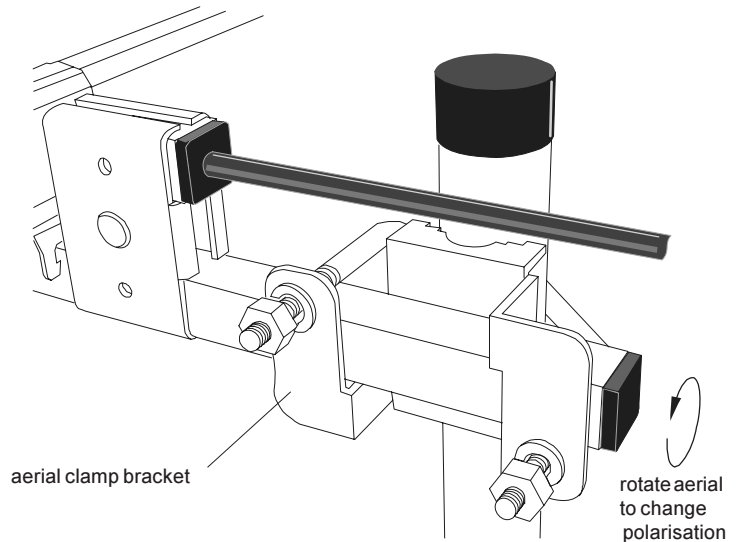

2. Fit 'F' connector to downlead cable

Prepare the cable end and fit the screw-on 'Type F' plug as shown. (The inner wire of the cable should extend slightly beyond the end of the plug.)

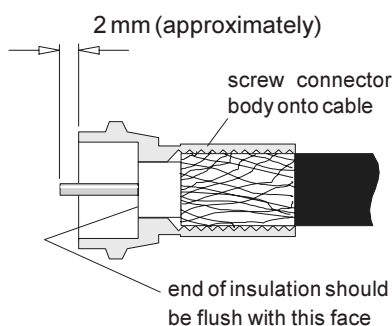
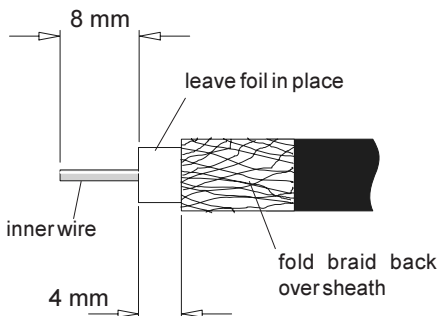

3. Connect cable to aerial

Offer up the Type 'F' plug on the 10m cable to the socket on the aerial lead. Ensure that the inner wire of the plug enters the centre contact of the socket. Screw the nut part of the plug onto the socket body and tighten, preferably using a pair of spanners (11 mm). **Do not leave the connector finger-tight as this may lead to unreliable reception.** Finally slide the waterproofing sleeve as far as it will go over the connectors. If the sleeve is tight on the aerial lead a little silicone grease or petroleum jelly can be applied as a lubricant. It is important that the sleeve and completed cable assembly are supported at or near the vertical in order to prevent water ingress.

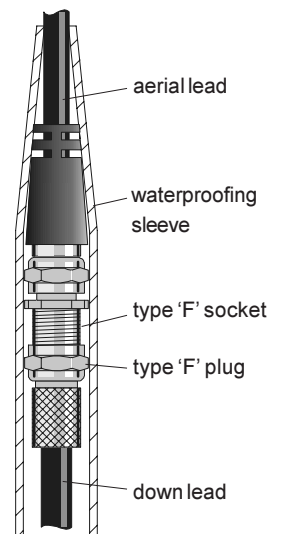

4. Secure mast to the caravan frame

Clamp the mast mounting bracket to the caravan 'A' frame in a convenient position and tighten the bolt and lock nut. The mast and aerial can now be fitted into position as shown. Push the bottom end of the mast into the ground first to ensure stability.

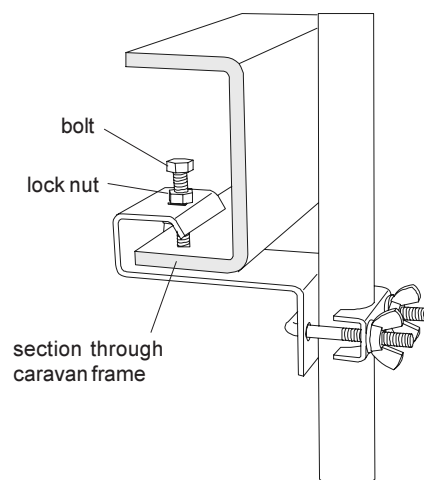

Kit contents

- Log-periodic aerial
- Three-section mast
- Aerial and support clamps
- Mast clamp bracket assembly
- 10 m cable
- Connectors (one 'F', one 'IEC')
- Instruction leaflet

5. Completing the installation

Choose horizontal or vertical polarisation (see diagrams) to suit the local transmitter. Point the aerial towards the transmitter. If in doubt look at aerials on neighbouring caravans or buildings, or consult one of the sources of transmitter information (see below).

Fit the IEC coaxial plug supplied (see below) and run the cable into the caravan through a suitable vent or opening, avoiding sharp bends. The cable, which can be shortened if desired, should be taped tidily down the mast as shown using PVC insulating tape (not supplied). Leaving the cable to dangle freely from the aerial should be avoided since it may lead to broken connections or water ingress. Plug the cable into your TV or *Freeview receiver.

Aerial installation for horizontally polarised transmission

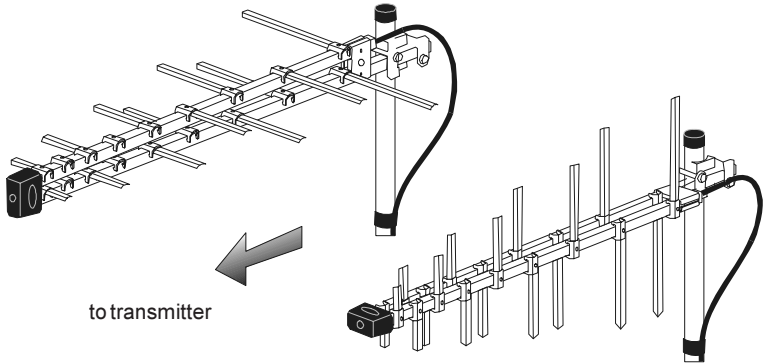

Aerial installation for vertically polarised transmission

Aerial lead and downlead taped to mast above and below cable joint

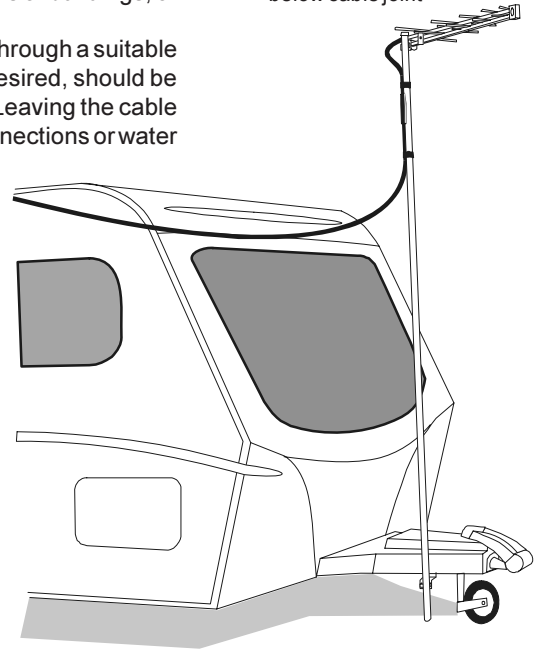

6. Reception hints

For optimum reception position the caravan on high ground with a clear view toward the transmitter site, avoiding trees. Wherever possible arrange that the aerial has to point away from the caravan body to 'see' the transmitter. Adjust the aerial by slackening the wing nuts on the lower mast clamp and rotating the whole mast for best reception. If using a *Freeview receiver use its signal quality display as an indicator to determine the best aerial pointing direction. Remember to tighten all clamps and fixings once adjustment is complete. If you have moved the caravan from an area served by a different transmitter your TV set and/or *Freeview receiver will almost certainly need to be retuned (refer to their instruction manuals) and the polarization of the aerial may need to be changed. Refer to the reception advice services listed on below for transmitter details for your new area. Some areas are served by two or more transmitters and it may be necessary to experiment to find which one gives the best results.

* Freeview is a registered trademark of DTV Services P.L.C.

7. Fitting the coaxial plug

a) First place the cap over cable. Strip away cable outer sheath. Take great care not to cut through the braid wires. Strip away insulation to reveal inner conductor.

b) Bundle the braid wires together and slide clamp over cable.

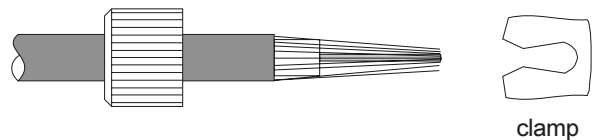
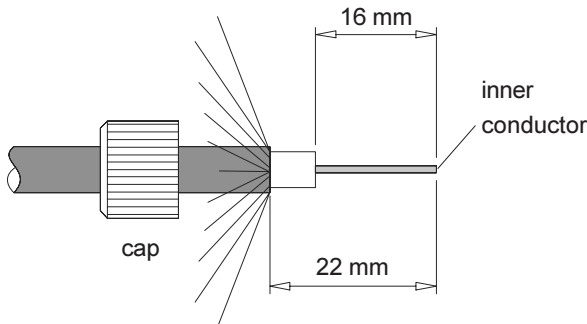

c) Dress the braid wires evenly over clamp. Push cable and clamp into connector body. *Ideally the inner conductor should be soldered to the contact pin. Screw cap and outer body securely together. This completes fitting the plug.

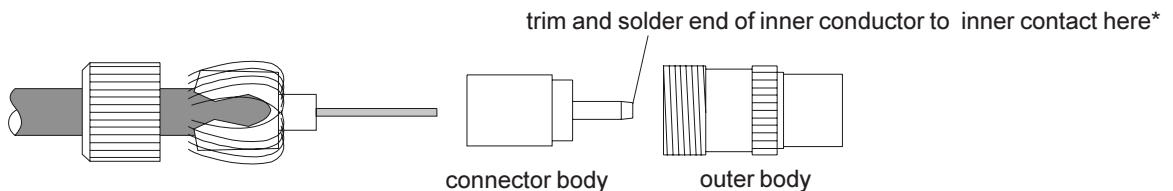

Further advice may be downloaded from:
www.blake-uk.com/downloads on the following:

- reception problems
- distributing TV signals around the home
- general recommendations

Reception Advice Services
 BBC Reception Advice 08700 100123
 e-mail: reception@bbc.co.uk
 web: www.bbc.co.uk/reception
 Ofcom – TV reception and interference
<http://www.ofcom.org.uk/consumer advice/tv/reception>